

## MODEL SG44D DOUBLE DECK GAS CONVECTION OVEN



Shown with optional casters



### SPECIFICATIONS:

Double section gas convection oven, Vulcan-Hart Model No. SG44D. Stainless steel front, sides, top, rear enclosure panel and legs. Independently operated stainless steel doors with windows open a full 180°. Non-sag insulation applied to the top, rear, sides, bottom and doors. Porcelain enamel on steel oven interiors measure 29"w x 22<sup>1</sup>/<sub>8</sub>"d x 20"h. Two interior oven lights per section. Five nickel plated oven racks per section measure 28<sup>1</sup>/<sub>4</sub>" x 21<sup>1</sup>/<sub>4</sub>". Eleven position nickel plated rack guides with positive rack stops. Two 30,000 BTU/hr. burners per section, 120,000 BTU/hr. total input. Electronic spark igniters. Furnished with two speed 1/2 H.P. oven blower motors. Side mounted solid state temperature controls adjust from 150° to 500°F. Power Level controls allows the operator to adjust the heat input from 15,000 BTU/hr. to a maximum input of 60,000 BTU/hr. in each oven section. 60 minute timers with audible alarm. Oven cool switch for rapid cool down. 115 volt, 60 Hz, 1 ph power supply required. 6' cord and plug. 9 amps per section, 18 amps total draw.

Exterior dimensions: 40"w x 41<sup>1</sup>/<sub>2</sub>"d x 72"h on 8" legs. Depth measurement includes door handles.

CSA design certified. NSF listed.

**SPECIFY TYPE OF GAS AND FINISH WHEN ORDERING.**

**SPECIFY ALTITUDE WHEN ABOVE 2,000 FT.**

### STANDARD FEATURES

- Stainless steel front, sides, top, rear enclosure panel and legs.
- Independently operated stainless steel doors with windows open a full 180°.
- Two 30,000 BTU/hr. burners per section, 120,000 BTU/hr. total input.
- Electronic spark igniters.
- 1/2 H.P. two speed oven blower motors. 115/60/1 with 6' cord and plug. 9 amps per section, 18 amps total draw.
- Solid state temperature controls adjust from 150° to 500°F.
- Energy saving "Power Level" controls allow the operator to adjust the heat input to the size of the load.
- 60 minute timers with audible alarm.
- Oven cool switch for rapid cool down.
- Porcelain enamel on steel oven interiors.
- Five nickel plated oven racks with eleven rack positions per section.
- 3/4" rear gas connection with combination gas pressure regulator and safety solenoid system.
- One year limited parts and labor warranty.

### OPTIONS

- Five hour timer in place of 60 minute timer.
- Casters.
- Second year extended limited parts and labor warranty contract.

### ACCESSORIES

- Extra oven rack(s).
- Stainless steel drip pans.
- Flexible gas hose with quick disconnect and restraining device. Consult price book for available sizes.
- Down draft flue diverter for direct vent connection.



# MODEL SG44D

## DOUBLE DECK GAS CONVECTION OVEN

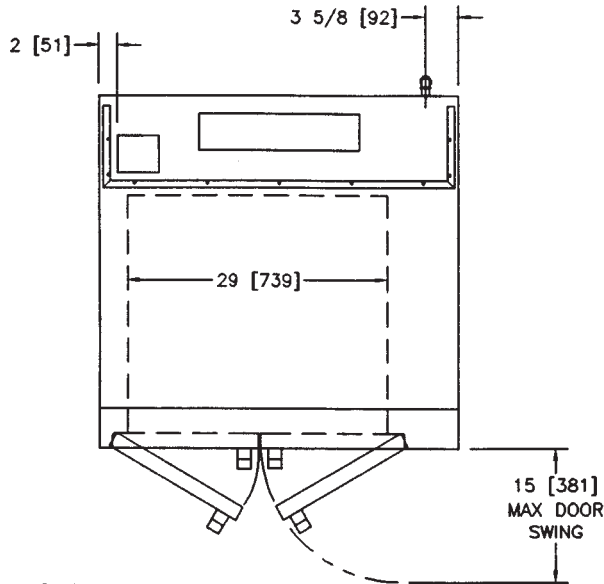

### IMPORTANT

1. A combination gas pressure regulator and safety solenoid system is included in this unit. Natural gas is 3.5" W.C., Propane gas is 10.0" W.C.
2. An adequate ventilation system is required for commercial cooking equipment. Information may be obtained by writing to the National Fire Protection Association, Batterymarch Park, Quincy, MA 02289. When writing, refer to NFPA No. 96.
3. These units are manufactured for installation in accordance with ANSZ223.1 (latest edition), National Fuel Gas Code. Copies may be obtained from the American Gas Association, 1515 Wilson Blvd., Arlington, VA 22209.
4. Clearances:
 

	Combustible	Non-combustible
Rear	6"	6"
Left Side	1"	0"
Right Side	4"	4"
5. This appliance is manufactured for commercial installation only and is not intended for home use.

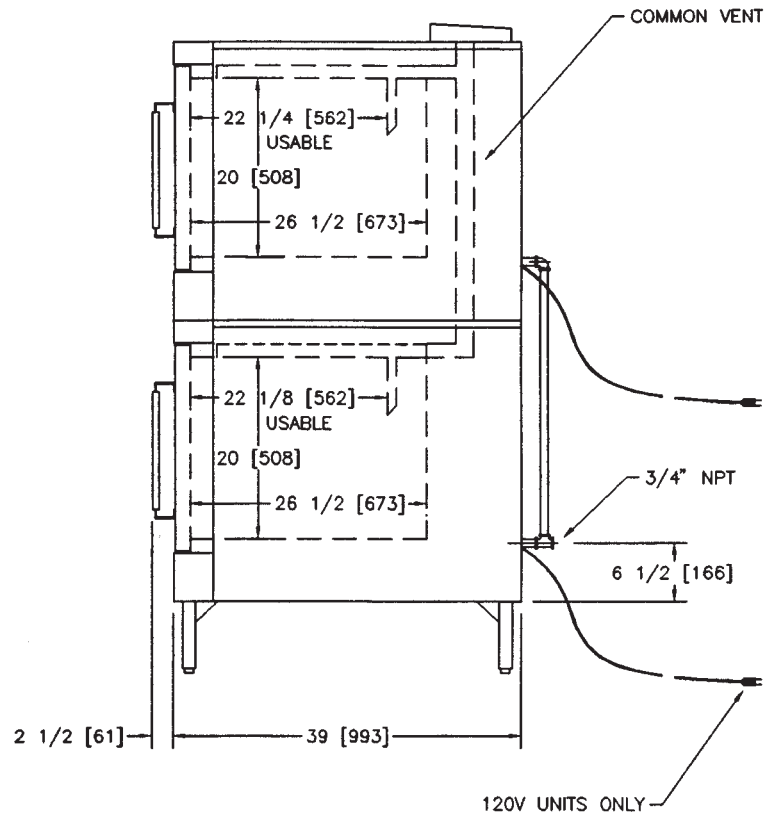
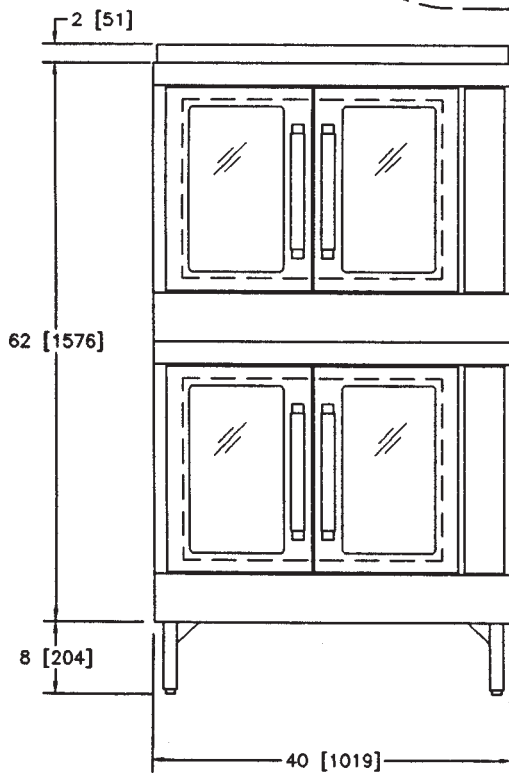

DOUBLE OVEN	Width	Depth (Includes handles)	Height	BTU/hr. Per Oven	Total BTU/hr.	Electrical	Approx. Shp. Wt. (lbs./kg)
SG44D	40"	41 1/2"	72"	60,000	120,000	115/60/1	1180/532

**NOTE:** In line with its policy to continually improve its products, Vulcan-Hart Company reserves the right to change materials and specifications without notice.