

Project _____

Item # _____

Quantity _____



GLOBE FOOD EQUIPMENT COMPANY

Automatic Slicer

4975



4975 Automatic Slicer

Protech™ Model

4975 - Variable Speed Slicer



Made in the U.S.A.

Standard Features

- Gear driven
- 1/2 HP knife motor, 7 amps
- Exclusive stainless steel construction
- Precision gear thickness adjustment
- Slices tissue thin up to 1 1/4" thick
- Table lockout
- Built in antimicrobial protection
- Knife cover interlock
- Signature knife sharpening system
- 12" hollow ground knife
- Permanently attached knife ring guard
- Full gravity feed, 45° angle
- 3 lb. stainless steel end weight
- Return to home food chute
- Home position start
- Automatic shut off
- Auto engage lever
- Touch pad controls
- Lift lever to facilitate cleaning
- Red indicator light
- No voltage release
- 7 foot cord and plug

Options and Accessories

- Prison package
- High moisture application package (includes stainless steel knife)
- 15" food chute in lieu of 12" chute
- Aluminum food chute in lieu of stainless steel chute
- Stainless steel knife in lieu of carbon steel
- Front mounted end weight assembly in lieu of standard end weight
- Low food fence
- High food fence
- 3" extension legs
- 10 lb. portion control scale
- Slicer cover

Standard Warranty

- 2 years parts and 1 year labor plus 15 years on the gears

Approved By: _____

Date: _____



GLOBE FOOD EQUIPMENT COMPANY

www.globeslicers.com

2153 Dryden Rd
Dayton, OH 45439
Phone: 937-299-5493
Phone: 800-347-5423
Fax: 937-299-4147



Automatic Slicer

4975

Specifications

Finish: Exclusive #304 stainless steel base with radiused corners improves sanitation and durability. Other stainless steel parts include the food chute, slicer table, end weight, and knife cover.

Motors: Knife Motor: Powerful 1/2 HP, 115/60/1, 7 amps. **Chute Motor:** Two speed DC fractional horsepower 1 amp. Both motors have permanently lubricated sealed ball bearings.

Knife Drive: Cross axis helical gear drive design. This positive drive design assures nonslip, trouble free operation.

Slice Thickness: Precision gear adjustment holds thickness setting for consistent cuts and allows hot or cold foods to be sliced from tissue thin up to 1 1/4" thick.

Antimicrobial Protection: Table adjustment knob, auto engage lever knob, sharpener cover knob, and food chute handle have antimicrobial protection built in.

Full Gravity Feed: Full 45° angle feed requires less mechanical pressure. Equipped with a 3 lb. stainless steel end weight to minimize waste and hold product. The end weight swings away for storage behind chute. The food chute handle is ergonomically designed.

Touch Pad Controls: Start/stop touch pad controls activate knife motor.
Chute Speed: Controlled by faster/slower touch pad controls.

Cord & Plug: Attached 7 foot flexible 3 wire cord and plug fits a grounded receptacle.

Lift Lever: A handle activates two large wheels, lifting the front of the unit to facilitate safe and easy cleaning underneath the slicer.

Knife Cover Interlock: Slicer will not operate with knife cover removed.

Return to Home Chute: Food chute automatically returns to position closest to the operator, home, when slicer is turned off. The chute must be in home position to start the slicer.

Table Lockout: Once table is closed and the knife cover is removed, the table cannot be opened. Fully protects knife during cleaning.

Automatic Shut Off: Slicer automatically shuts off after 10 seconds of no chute movement.

Knife Ring Guard: Permanently mounted knife ring guard protects the non-slicing portion of the knife. Slicer table protects leading edge of knife when completely closed.

Top Mounted Sharpener: Sharpener is made of all metal and is permanently mounted on the slicer. A single lever activates the large grinding and honing stones.

Hollow Ground Knife: Nominal 12" diameter special hardened steel alloy with stain resistant finish and sanitary hub.

No Voltage Release: Prevents inadvertent reactivation of slicer in the event of power or interlock interruption. Operator must restart slicer.

Capacity: 8.75"H x 12.5"W or 7 1/2" Dia. (22.2cm x 31.8cm or 19cm)

Red Indicator Light: A readily visible light illuminates when knife is rotating.

Automatic Chute: Chute travels 20 to 60 strokes per minute utilizing a separate DC motor with a heavy duty permanently lubricated chain and sprocket drive system. Chute can quickly be engaged or disengaged for manual operation with the auto engage lever.

Dimensions:
Foot Print = 14" x 21.62"
(35.6 cm x 54.9 cm)
Overall Length = 28.25" (71.8 cm)
Overall Width = 21.5" (54.6 cm)
Overall Height = 24" (61 cm)
Freight Class: 77.5
Net Weight: 153 lbs. (69.4 kgs.)
Shipping Weight: 165 lbs. (74.7 kgs.)
Shipping Dimensions:
28"W x 25"D x 34"H
(71.1cm W x 63.5cm D x 86.4cm H)

Factory Installed Options:
LONGCHUTE 15" food chute
SSK Stainless steel knife
FMEW Front mounted end weight
ALUM Aluminum food chute
MEATROOM High moisture application package
PRISON Prison package

Accessories:
1326 High fence (12" x 3")
1047 Low fence (12" x 1 3/8")
873-SET 3" extension legs
PS10 10 lb. Portion control scale
SC-GLOBE Slicer cover

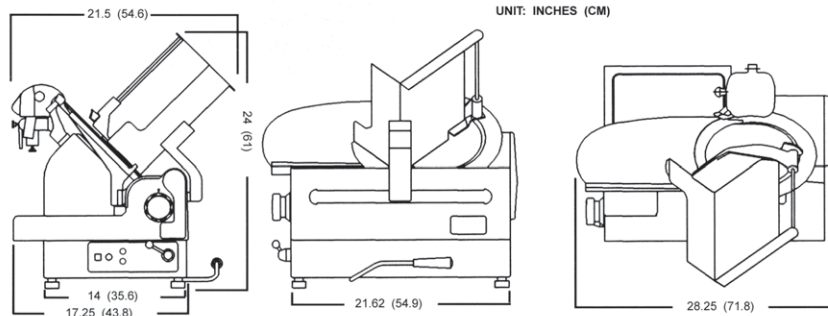

GLOBE FOOD EQUIPMENT COMPANY
www.globeslicers.com

2153 Dryden Rd
Dayton, OH 45439
Phone: 937-299-5493
Phone: 800-347-5423
Fax: 937-299-4147

Printed in U.S.A. 10-2005

Specifications are subject to change without notice.